

HASSLACHER
NORICA TIMBER

From **wood** to **wonders**.

EXCELLENT- SURFACE FOR CROSS LAMINATED TIMBER

NEW

THE INNOVATION IN SURFACE.



EXCELLENTSURFACE

THE INNOVATION

HASSLACHER NORICA TIMBER is a pioneer in the development of different surfaces for cross laminated timber.

With its excellent lamellas, new standards are set regarding surface gaps and cracks. This is possible due to the crossed structure. In the frame of structural design, the excellent lamella can be calculated in the same way as a conventional lamella in solid timber. This circumstance also applies to structural fire design.

YOUR ADVANTAGES

- ⊕ The highest housing quality in the surface
- ⊕ The gap formation is considerably reduced.
- ⊕ Almost no cracking in the cover lamellas
- ⊕ The excellent lamella can, if desired, also be edge bonded.

A WIDE RANGE OF APPLICABLE WOODS SPECIES

The new excellent lamella also enables the use of several different wood species and best wood qualities – all cost-optimised.

EXCELLENT LAMELLA SOFTWOOD

- ⊕ Spruce
- ⊕ Fir
- ⊕ Larch
- ⊕ Pine
- ⊕ Arolla pine

EXCELLENT LAMELLA HARDWOOD

- ⊕ Birch
- ⊕ Oak
- ⊕ Other hardwood species on request

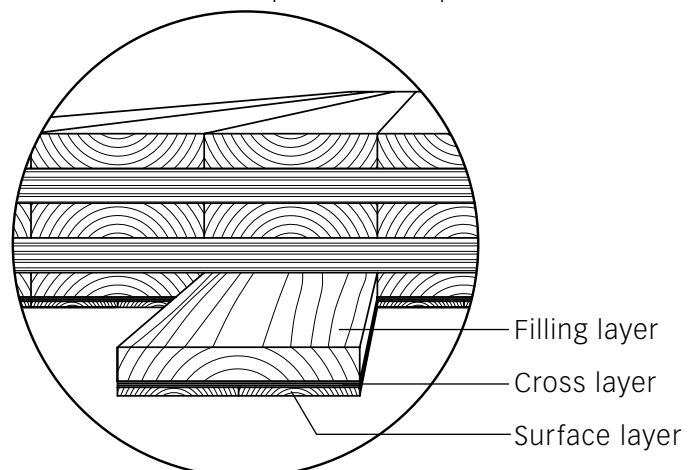

HASSLACHER
NORICA TIMBER

From **wood** to **wonders**.



In 2014, the architect Herwig Ronacher decided to build – in addition to his office in Kluenburg near Hermagor – a new office complex with six holiday homes in Annenheim, on the Lake Ossiach. These six holiday apartments are located in the immediate vicinity of the Gerlitzten Kanzelbahn with a clear view to the Ossiacher See. Along with the interior design they shall promote the processing quality to guests and interested customers.

The walls in cross laminated timber were made with arolla pine and oak excellent surface lamellas. For the external balconies, glue laminated larch timber was used.

PROJECT INFORMATION: SINGLE-FAMILY HOUSE RASER

Location	Annenheim
Client:	Holzbau Pichler Gundersheim
Project planner:	Architect Ronacher ZT GmbH
Statics and construction:	Graduate engineer Markus Lackner
Building contractor:	Freunschlag & Ronacher ZT GmbH
Year of construction:	2015
Utilised products:	Excellent surface cross laminated timber made of spruce, arolla pine and oak. Glue laminated larch timber

From **wood** to **wonders**.

HASSLACHER group
Feistritz 1 | 9751 Sachsenburg | Austria
T +43 4769 22 49-0 | F +43 4769 22 49-129
info@hasslacher.com | hasslacher.com

HNT0103_EN_201908

HASSLACHER
NORICA TIMBER
From **wood** to **wonders**.